

Installation,
Operation, and Maintenance
Manual



Flygt 2151.011, 2151.011-U

FLYGT
a xylem brand

GUARANTEE

Xylem undertakes to remedy faults in products sold by Xylem provided:

- ▣ that the fault is due to defects in design, materials or workmanship;
- ▣ that the fault is reported to Xylem or Xylem's representative during the guarantee period;
- ▣ that the product is used only under conditions described in the care and maintenance instructions and in applications for which it is intended;
- ▣ that the monitoring equipment incorporated in the product is correctly connected;
- ▣ that all service and repair work is done by a workshop authorized by Xylem;
- ▣ that genuine Flygt parts are used.

Hence, the guarantee does not cover faults caused by deficient maintenance, improper installation, incorrectly executed repair work or normal wear and tear.

Xylem assumes no liability for either bodily injuries, material damages or economic losses beyond what is stated above.

Xylem guarantees that a spare parts stock will be kept for 10 years after the manufacture of this product has been discontinued.

The manufacturer reserves the right to alter performance, specification or design without notice.

DATA PLATE INTERPRETATION

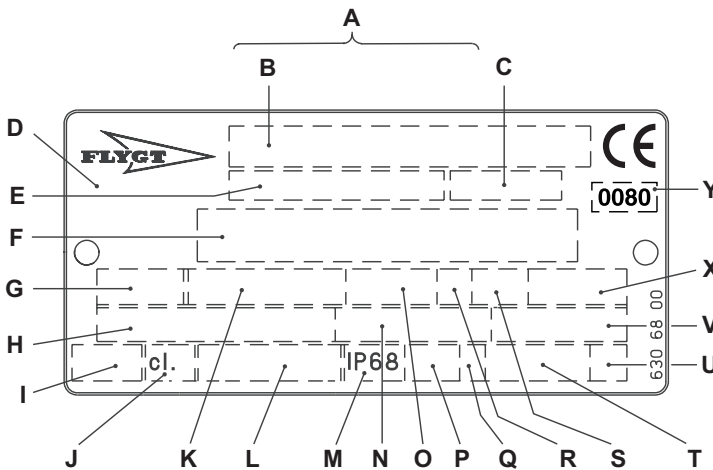

- A Serial number
- B Product code + Number
- C Curve code / Propeller code
- D Country of origin
- E Product number
- F Additional information
- G Phase; Type of current; Frequency
- H Rated voltage
- I Thermal protection
- J Thermal class
- K Rated shaft power
- L International standard
- M Degree of protection
- N Rated current
- O Rated speed
- P Max. submergence
- Q Direction of rotation: L=left, R=right
- R Duty class
- S Duty factor
- T Product weight
- U Locked rotor code letter
- V Power factor
- X Max. ambient temperature
- Y Notified body/Only for EN-approved Ex-products

CONTENTS

Product description _____	3	Care and maintenance _____	11
Applications _____	3	Safety precautions _____	11
Dimensions and weights _____	3	Inspection _____	11
Design _____	3	Changing the oil _____	14
Technical data _____	4	Replacing the impeller _____	14
Transportation and storage _____	5	Accessories and tools _____	19
Installation _____	5	Fault tracing (Troubleshooting) _____	20
Safety precautions _____	5	Service log _____	24
Pump installation _____	5	Exploded view _____	26
Electrical connections _____	6		
Operation _____	10		

PRODUCT DESCRIPTION

Applications

2151.011 is intended to be used for pumping of water which may contain abrasive particles.

Liquid temperature: max. 40°C (103°F).

The pump is also available in POLY-LIFE version, 2151.011-U, with polyurethane coated wear parts.

Liquid density: Max. 1100 kg/m³ (9.2 lb per US gal).

The pumped liquid may contain particles up to a size which corresponds to the openings in the strainer.

The pH of the pumped liquid: 5-8.

Depth of immersion: max. 20 m (66 ft).



WARNING!
The pump shall not be used in explosive or flammable environments or with flammable liquids.



NOTE!
Make sure that the monitoring equipment incorporated in the product is correctly connected.

For other applications, contact your nearest Xylem representative for information.

Dimensions and weights

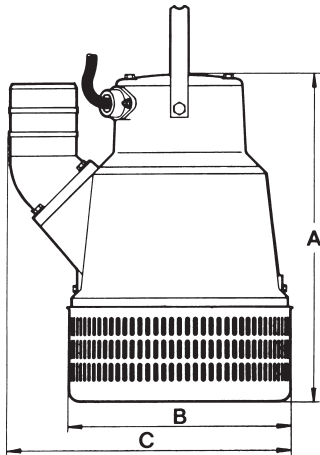

A = 745 mm (293") B = 505 mm (199") C = 640 mm (252")

Weight without motor cable: 165 kg (364 lb).

Rated output 20 kW
3 ~ 50 Hz, 2900 r/min

Voltage V	Rated current A	Starting current A
220	66	430
380	38	250
400	36	315
440	33	240
500	29	170

Rated output 22 kW (30 hp)
3 ~ 60 Hz, 3500 r/min

Voltage V	Rated current A	Starting current A
220	72	500
230 Y//	68	440
440	36	250
460 Y ser.	34	220
575	27	175

Design

2151.011 is a submersible, electric motor-driven pump.

Impellers

The pump is available with the following types of impellers:

radial-flow impeller of chromium-alloyed cast iron (HT).

mixed-flow impeller of chromium-alloyed cast iron (LT, MT).

Shaft seals

The pump has two mechanical seals which provide the isolation necessary between the electric motor and the pumped liquid.

Materials:

Inner seal: Corrosion resistant cemented carbide/
corrosion resistant cemented carbide.

Outer seal: Corrosion resistant cemented carbide/
corrosion resistant cemented carbide.

Shaft

Shaft material: carbon steel.

Bearings

The pump bearings are designed for at least 16 000 hours of operation.

The lower bearing consists of a deep-groove ball bearing.

The upper bearing consists of a double-row angular contact ball bearing.

Oil casing

The oil lubricates and cools the seals and acts as a buffer between the pump casing and the electric motor.

Pressure build-up within the oil casing is reduced by means of a built-in air volume.

Motor

Squirrel-cage 3-phase induction motor for 50 Hz or 60 Hz.

The motor is started by means of direct on-line start or star-delta start.

The motor can be run continuously or intermittently with a maximum of 15 evenly spaced starts per hour.

The stator is insulated in accordance with IEC, class F, 155°C (310°F). The motor is designed to supply its rated output at ± 5% variation of the rated voltage without overheating the motor, ± 10% variation of the rated voltage can be accepted provided that the motor does not run continuously at full load. The motor is designed to operate with a voltage imbalance of up to 2% between the phases (according to IEC 34.1).

Monitoring equipment

The stator incorporates three thermal switches connected in series.

The thermal switches open at 125°C (260°F).

Cooling

The stator is cooled by the pumped liquid passing through the space between the stator casing and the outer casing.

Technical data

The pump curves below show:

- input power at various operating points.
- flow rate versus total head.

The following abbreviations are used:

- LT = low-head version
- MT = medium-head version
- HT = high-head version

For further information, see "Parts list".

50 Hz

LT = Curve No. 231

MT = Curve No. 241

HT = Curve No. 233

60 Hz

MT = Curve No. 232

HT = Curve No. 234

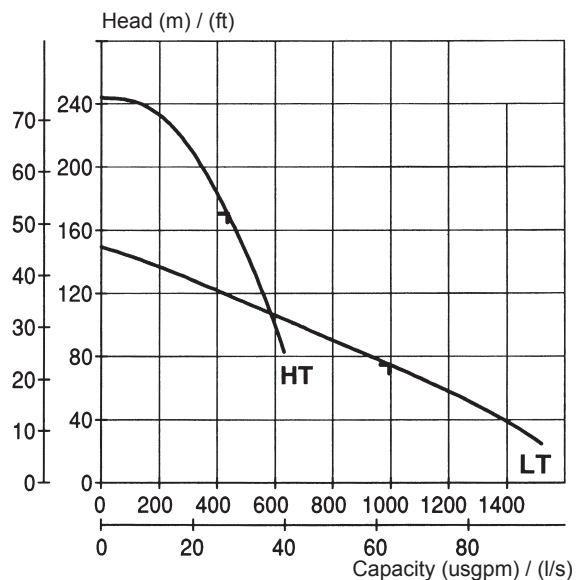
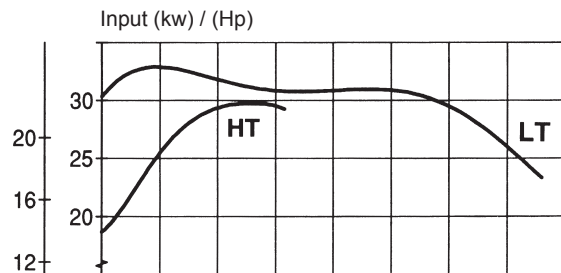
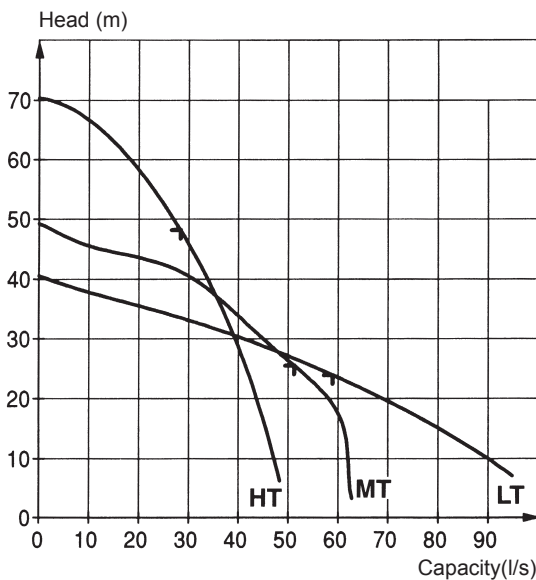
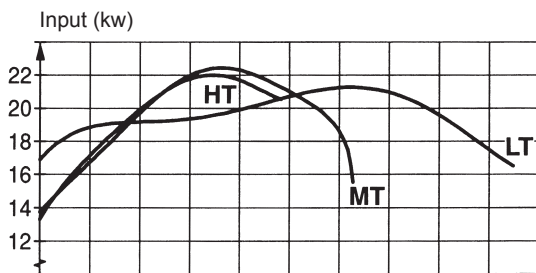

TRANSPORTATION AND STORAGE

The pump may be transported and stored in a vertical or horizontal position. Make sure that it cannot roll or fall over.



WARNING!
Always lift the pump by its carrying handle or lifting eyes, never by the motor cable or the hose.

The pump is frostproof as long as it is operating or is immersed in the liquid. If the pump is taken up when the temperature is below freezing, the impeller may freeze. The pump shall be operated for a short period after being taken up in order to expel all remaining water.

A frozen impeller can be thawed by allowing the pump to stand immersed in the liquid for a short period before it is started. Never use an open flame to thaw the pump.

For longer periods of storage, the pump must be protected against moisture and heat. The impeller should be rotated by hand occasionally (for example every other month) to prevent the seals from sticking together. If the pump is stored for more than 6 months, this rotation is mandatory.

After a long period of storage, the pump should be inspected before it is put into operation. Pay special attention to the seals and the cable entry.

Follow the instructions under the heading "Before starting".

INSTALLATION

Safety precautions

In order to minimize the risk of accidents in connection with the service and installation work, the following rules should be followed:

1. Make sure the lifting equipment is in good condition.
2. Be aware of the risk of electrical accidents.
3. Use a safety helmet, safety goggles and protective shoes.
4. Do not ignore the risk of drowning.
5. A first-aid kit must be handy.

Follow all other health and safety rules and local codes and ordinances.



At certain installations and operation points on the pump curve the noise level 70 dB, or for the actual pump specified noise level, can be exceeded.

Pump installation

Run the cables so that they do not have any sharp bends and are not pinched.

Connect the discharge connection and motor cable. See "Electrical connections".

Lower the pump into the sump.

Place the pump on a base which will prevent it from sinking into a soft sump bottom. Alternatively, the pump can be suspended by its handle just above the sump bottom.

For tandem connection of pumps, see "Accessories and tools".

Consult your nearest Xylem representative regarding:

- choice of peripheral equipment.
- other problems in connection with installation.

Mount U-sectional holders (113) as below.

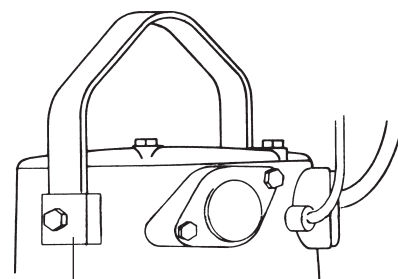

113



WARNING:
CRUSH HAZARD
Never put your hand into the pump housing.

ELECTRICAL CONNECTIONS

Local codes and regulations shall be complied with.



WARNING!

All electrical equipment must be earthed. This applies to both pump equipment and any monitoring equipment. Failure to heed this warning may cause a lethal accident. Make sure that the earth lead is correctly connected by testing it.

Check that the main (line) voltage and frequency agree with the specifications on the pump data plate.

The motor can be connected for different voltages as shown on the data plate.

Install the motor cable and the control cable as illustrated in the exploded figure.

To avoid leakage into the pump, check:

- that the cable entry seal sleeve and washers conform to the outside diameter of the cable. See the parts list.
- that the outer jacket on the cable is not damaged. When refitting a cable which has been used before, **always** cut off a short piece of the cable so that the cable entry seal sleeve does not close around the cable at the same point again.



NOTE!

For safety reasons, the earth lead should be approx. 70 mm (2³/₄) longer than the phase leads. If the motor cable is jerked loose by mistake, the earth lead should be the last lead to come loose from its terminal. This applies to both ends of the cable.

Check on the data plate which connection, Y or Δ, is valid for the voltage supply. Then depending on voltage, arrange the connection on the terminal board in accordance with the figures.

Connect the motor cable as illustrated in the figures.

Connect the control leads from the motor control circuit to T1 and T2.

Make sure that the pump is correctly earthed (grounded).

Install the cover (59).

Tighten the nuts (21) so that the cable entry unit bottoms out.

Connect the motor cable to the starter equipment. Check the direction of rotation, see "Before starting".

If the direction of rotation is wrong, transpose two of the phase leads.

The tables on page 3 give rated current and starting current. Fuse amperage and cable shall be selected in accordance with local rules and regulations. Note that with long cables, the voltage drop in the cable must be taken into consideration, since the motor's rated voltage is the voltage that is measured at the terminal board in the pump.

The overload protection (motor protection breaker) shall always be set to the motor's rated current as given on the data plate.

Remember that the starting surge with the direct-on line start can be up to six times higher than the rated current. Make sure that the fuses or circuit breakers are of the proper amperage.



NOTE!

Make sure that the monitoring equipment incorporated in the product is correctly connected.

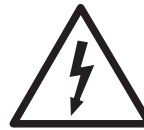

WARNING:

ELECTRICAL HAZARD

Risk of electrical shock or burn. You must connect an additional ground-(earth-) fault protection device to the grounded (earthed) connectors if persons are likely to come into contact with liquids that are also in contact with the pump or pumped liquid.

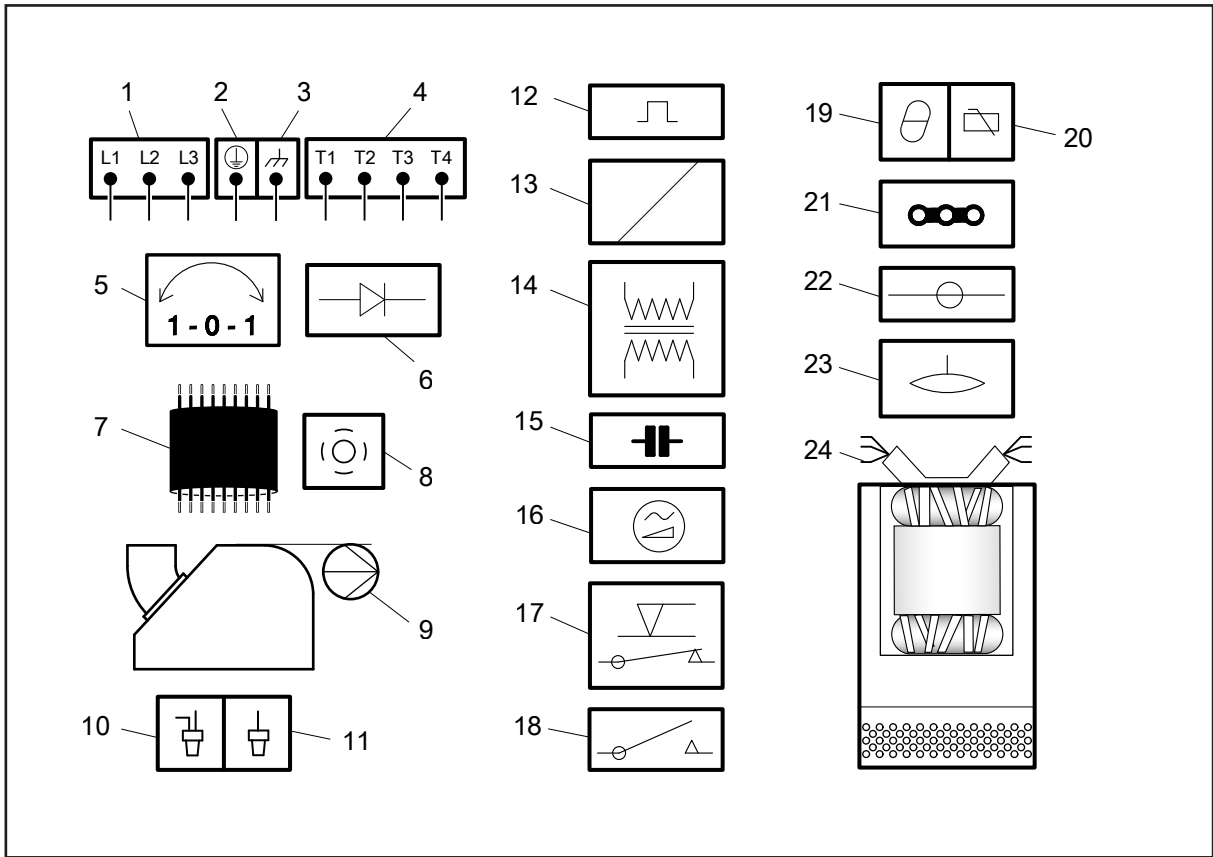

1	Starter equipment and main leads (L1, L2, L3)	13	Coil
2	Earth (ground)	14	Transformer
3	Functional ground	15	Capacitor
4	Control leads (T1, T2, T3, T4)	16	Softstarter
5	Phase shifter	17	Level regulator
6	Diode	18	Contactors, start relay or thermal relay
7	Motor cable	19	Thermal detector in stator
8	Screen	20	Thermal detector in main bearing
9	Pump	21	Jumper
10	Crimp connection	22	Terminal board, terminal plate
11	Crimp isolation	23	Leakage sensor
12	Motor protector	24	Stator leads (U1, U2, U5, U6, V1, V2, V5, V6, W1, W2, W5, W6, Z1, Z5, Z6)

CABLE CHART

BN	Brown
BK	Black
WH	White
OG	Orange
GN	Green
GNYE	Green-Yellow
RD	Red
GY	Grey
BU	Blue
YE	Yellow

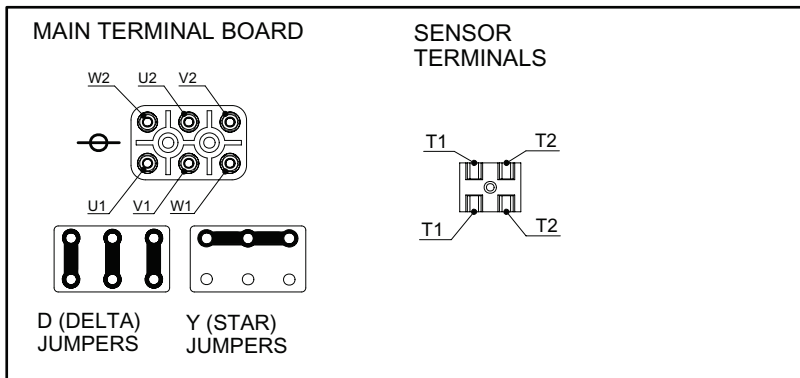

MOTOR CABLE CONNECTION TO TERMINALBOARD 3-PH →

	Screen as ground conductor Functional ground to GC S3xA+3xA/3+S(4x0,5)	Functional ground to GC 4GA+S(2x0,5)	Screen as ground conductor S3xA+3xA/3+4x1,5	FGB 3xA	4GA+2x1,5	4GA	A AWG/3-2-1-GC	A AWG/4	Terminal board
L1	BN	BN	BN	BN	BN	BN	RD	RD	U1
L3	GY	GY	GY	GY	GY	GY	WH	WH	V1
L2	BK	BK	BK	BK	BK	BK	BK	BK	W1
									W2
									U2
									V2
	T1 WH	T1 WH	T1 WH		T1 WH		OR		ALT. T1
	T2 WH	T2 WH	T2 WH		T2 WH		BU		ALT. T2
	T3 WH		T3 WH						
	T4 WH		T4 WH						
					GNYE	GNYE	GNYE	GNYE	
							YE	YE	GC

MOTOR CABLE CONNECTION TO TERMINALBOARD 3-PH →

	Y/D 7GA+S(2x0,5)	Screen as ground conductor FGB 6xA+2x1,5	7GA+2x1,5	Terminal board	3 leads Y	6 leads D	6 leads Y	6 leads Y/D	9 leads Y serial	9 leads Y //	12 leads Y //	12 leads Y serial
L1	BK 1	1 WH	BK 1	U1	U	U1	U1	U1	U1	U1 U5	U1 U5	U1
L3	BK 3	3 WH	BK 3	V1	V	V1	V1	V1	V1	V1 V5	V1 V5	V1
L2	BK 2	2 WH	BK 2	W1	W	W1	W1	W1	W1	W1 W5	W1 W5	W1
L1	BK 4	4 WH	BK 4	W2	-	W2	W2	U2 U5	U2	U2	U2	U2 U5
L3	BK 6	6 WH	BK 6	U2	-	U2	U2	V2 V5	V2	V2	V2	V2 V5
L2	BK 5	5 WH	BK 5	V2	-	V2	V2	W2 W5	W2	W2	W2	W2 W5
	T1 WH	T1 WH	T1 WH	ALT. T1	T1	T1	T1	T1	T1	T1	T1	T1
	T2 WH	T2 WH	T2 WH	ALT. T2	T2	T2	T2	T2	T2	T2	T2	T2
											U6 V6 W6	U6 V6 W6
			GNYE									

SENSORS

MAX 250v
MAX 6A, cos φ=0,6
MAX 10A, cos φ=1

T1 — WH
T2 — WH

THERMAL
DETECTORS
IN STATOR

OPERATION

Before starting

Check that the oil reaches up to the oil hole.
Check that the monitoring equipment (if any) works.
Check the direction of rotation. See the figure.
The impeller shall rotate clockwise, as viewed from above. When started, the pump will jerk in the opposite direction to the direction in which the impeller rotates.

The above measures are described under "Inspection".



WARNING!
Watch out for the starting jerk,
which can be powerful.

Starting jerk

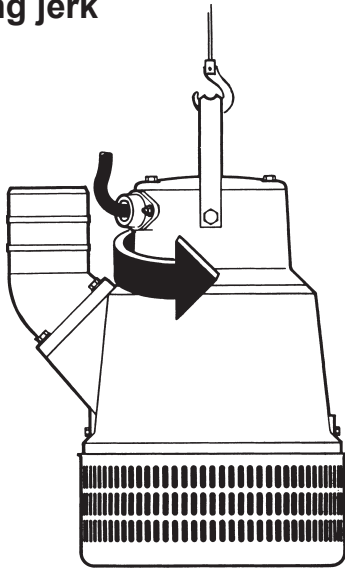

In order to avoid sedimentation when the pumped medium contains solid particles, the velocity of the medium in the discharge line should be:

Mixture	Min. velocity in discharge line
1. Water + coarse gravel	4.0 m/s (13.2 ft/s)
2. Water + gravel	3.5 m/s (11.5 ft/s)
3. Water + sand	
Sand particles <0.1 mm (0.004")	1.5 m/s (5.0 ft/s)
Sand particles <0.6 mm (0.024")	2.5 m/s (8.2 ft/s)

The pump can be provided with level regulation in order to prevent unnecessary wear on the hydraulic components.

Cleaning

If the pump has been running in very dirty water, let it run for a while in clean water, or flush it through the discharge connection. If clay, cement or other similar dirt is left in the pump it may clog the impeller and sealings, preventing the pump from working.

CARE AND MAINTENANCE

The figures in parentheses are item numbers and refer to the cutaway figure.

Safety precautions



WARNING!
Before starting work on the pump, make sure that the pump is isolated from the power supply and cannot be energized.

NOTE! This applies to the control circuit as well.

The following points are important in connection with work on the pump:

- make sure that the pump has been thoroughly cleaned.
- follow local safety regulations.



CAUTION:
THERMAL HAZARD
Allow surfaces to cool before starting work, or wear heat-protective clothing.



CAUTION:
CRUSH HAZARD
Make sure that the unit cannot roll or fall over and injure people or damage property.

Inspection

Regular inspection and preventive maintenance ensure more reliable operation.

The pump should be inspected at least every 2 000 hours of operation, more frequently under severe operating conditions.

Under normal operating conditions, the pump should have a major overhaul in a service shop annually.



This requires special tools and should be done by an authorized service shop.

When the pump is new or when the seals have been replaced, inspection is recommended after one week of operation.

Service contract

Xylem or its agent offers service agreements in accordance with a preventive maintenance plan. For further information, please contact your Xylem representative.

Recommended inspections:

Inspection of	Action
Visible parts on pump and installation	<p>Replace or fix worn and damaged parts.</p> <p>Make sure that all screws, bolts and nuts are tight.</p> <p>Check the condition of carrying handle/lifting eyes, chains and wire ropes.</p> <p>Wear on the impeller and the parts around it necessitates fine adjustment of the impeller or replacement of worn parts. See "Replacing the impeller" and "Replacing the diffuser".</p>
Oil quantity	<div data-bbox="453 448 1442 600" style="border: 1px solid black; padding: 5px;">  <p>WARNING! If the seal leaks, the oil casing may be under pressure. Hold a rag over the oil casing screw in order to prevent splatter. See "Safety precautions" for additional information.</p> </div> <p>Check that the oil reaches up to the oil hole when the pump is lying down with the oil hole up.</p> <p>Add oil as needed. See "Changing the oil".</p>
Condition of the oil	<p>A check of the condition of the oil can show whether there has been an increased leakage. (Note! Air/oil mixture can be confused with water/oil mixture).</p> <p>Insert a tube (or hose) into the oil hole. Cover the top end of the tube and take up a little oil from the bottom.</p> <p>Change the oil if it contains too much water, i.e., is heavily emulsified (cream-like), or if the water has settled out. See "Changing the oil". Check again one week after changing the oil.</p> <p>If the oil contains too much water again, the fault may be:</p> <ul style="list-style-type: none"> □ that an oil screw (43) is not sufficiently tight. □ that the O-ring (30) or its sealing surface is damaged. □ that the lower seal (77) is damaged. Contact a Xylem service shop.
Liquid in the stator casing	<div data-bbox="453 1178 1442 1330" style="border: 1px solid black; padding: 5px;">  <p>WARNING. If there has been leakage, the stator casing may be under pressure. Hold a rag over the inspection screw to prevent splatter. See "Safety precautions" for additional information.</p> </div> <p>Remove the plug (INSP), the inspection screw and the O-ring.</p> <p>Tilt the pump so that any liquid in the stator casing can run out through the hole.</p> <p>If there is water in the stator casing, the cause may be:</p> <ul style="list-style-type: none"> □ that the inspection screw (43) is not sufficiently tight. □ that an O-ring is damaged. □ that the cable entry is leaking. <p>If there is oil in the stator casing, the cause may be:</p> <ul style="list-style-type: none"> □ that the inner seal (67) is damaged. Contact a Xylem service shop. □ that an O-ring is damaged.

Inspection of	Action
Cable entry	<p>Make sure that the cable clamps are tight.</p> <p>If the cable entry leaks:</p> <ul style="list-style-type: none"> □ check that the entry is tightened so it bottoms out. □ cut a piece of the cable off so that the seal sleeve (106) closes around a new position on the cable. □ replace the seal sleeve. □ check that the seal sleeve and the washers (105) conform to the outside diameter of the cables.
Cables	<p>Replace the cable if the outer jacket is damaged. Make sure that the cables do not have any sharp bends and are not pinched.</p>
Level sensors or other level equipment	<p>Check function. Clean, adjust, replace or repair damaged level sensing equipment. Follow the instructions for the level sensing equipment in question.</p>
Starter equipment	<p>If faulty, contact an electrician.</p>
Rotation direction of pump (requires voltage)	<p>Transpose two phase leads if the impeller does not rotate clockwise as viewed from above. Rotation in the wrong direction reduces the capacity of the pump and the motor may be overloaded. Check the direction of rotation every time the pump is reconnected.</p>
Hose, valves and other peripheral equipment	<p>Repair faults and notify supervisor of any faults or defects.</p>
Insulation resistance in the stator	<p>Contact a Xylem service shop.</p>

Changing the oil



WARNING. If the seal leaks, the oil casing may be under pressure. Hold a rag over the oil plug to prevent splatter.

Lay the pump on its side on a bench or over two supports.

Unscrew the oil casing screw (43).

Turn the pump so that the hole faces downwards.

It is easier to drain the oil if the other oil hole screw is also removed.

In order to get out all the oil, the pump must be raised upright for a short while during drainage.

Fill up with 4 litres (4.2 US quarts) of new oil. Always replace the O-rings of the oil hole screws. Put the screws back and tighten them. Tightening torque 20-30 Nm (15-22 ft lb).

A paraffin oil with viscosity close to ISO VG32 is recommended. The pump is delivered from the factory with this type of oil. In applications where poisonous properties are of less concern, a mineral oil with viscosity up to ISO VG32 can be used.

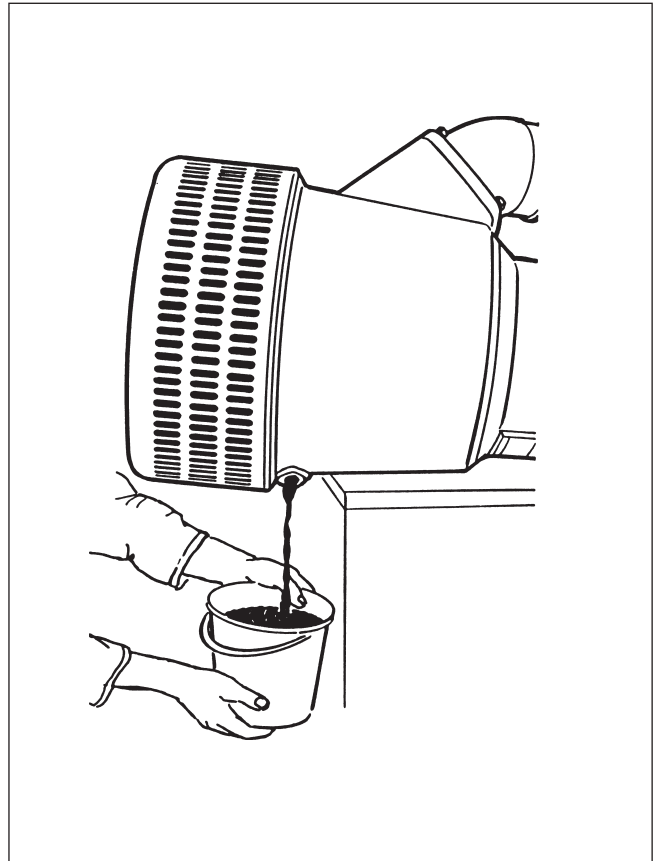

Replacing the impeller

The POLY-LIFE version of this pump has a product code ending with U, (see the data plate on the pump). Make sure that spare parts with spare part numbers marked (U), in the spare parts list, are used.

When the new wear parts are fitted, a clearance must be provided between the impeller and the oil casing bottom and between the impeller and the lower diffuser. The clearance should be 0.2-0.3 mm.

Check after fitting that the impeller can rotate freely.

The polyurethane covering is extremely resistant to wear. If the impeller does not rotate completely freely, friction will generate a great deal of heat. The result can be that the wear parts are deformed or that the impeller gets stuck, resulting in damages to the pump.

Removing the impeller



WARNING!
Worn impellers often have
very sharp edges.

Remove the junction box cover. Turn over the pump and stand it on the junction box.

Remove the nuts and pull off the strainer.

Remove springs, sleeves and pipes.

Remove the nuts and the lower diffuser.

Remove the nuts.

Remove the nuts and the diffuser ring.

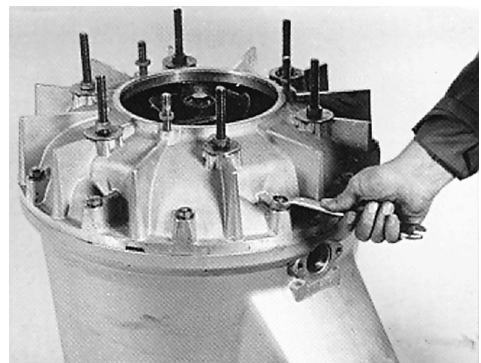
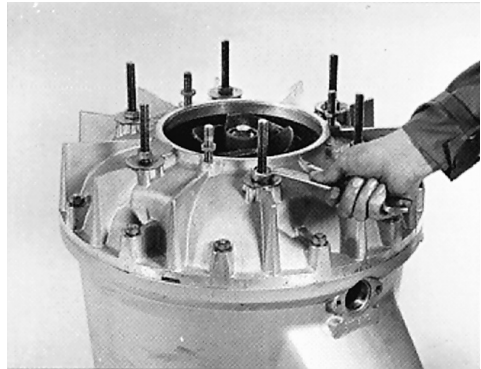
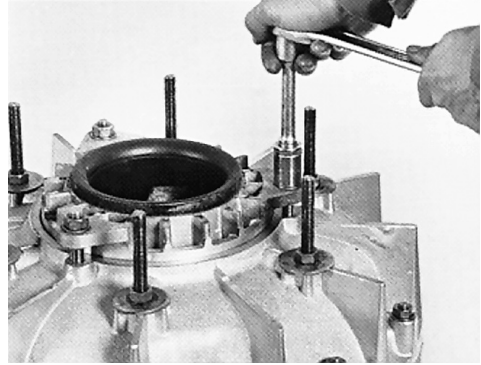

If the diffuser is difficult to lift off, put back the lower diffuser and secure it with three nuts. Pull off the diffuser with puller 84 13 60.



Unscrew the impeller screw and remove the washer.



Fit a screw, 81 40 21 (M16) into the threaded washer located under the impeller screw.



Mount the screw with the threaded washer.
Pull off the impeller.
Do **not** pry off the impeller, since it can easily be damaged.



Installing and adjusting of the impeller

Make sure that the end of the shaft is clean and free of burrs. Polish off any flaws.

Put on the diffuser and tighten it with the nuts.

Don't forget the large washers underneath.

Fit the key and then the necessary number of adjusting washers on the shaft to obtain minimum clearance between the impeller and the oil casing bottom.

Grease end of shaft.

Fit the impeller, the special washer in the impeller hub and the washer and impeller screw.

Press the impeller onto the shaft with the impeller screw.

Tighten the impeller screw.

Tightening torque 75 Nm (55 ft lb).

The clearance between the impeller and the oil casing bottom should be minimal when the impeller is tightened.

Check that the impeller can easily be rotated by hand.

Place the three adjusting nuts far down on the studs for the lower diffuser. Put the O-ring on the lower diffuser. Fit the lower diffuser and press it against the impeller. Screw the adjusting nuts flush up against the lower diffuser.

Back off all adjusting nuts another half-turn (counter-clockwise).

Place the washers and the nuts on the studs.

Tighten the nuts evenly all around.

The clearance between the impeller and the lower diffuser shall be as little as possible.

Check that the impeller can easily be rotated by hand.

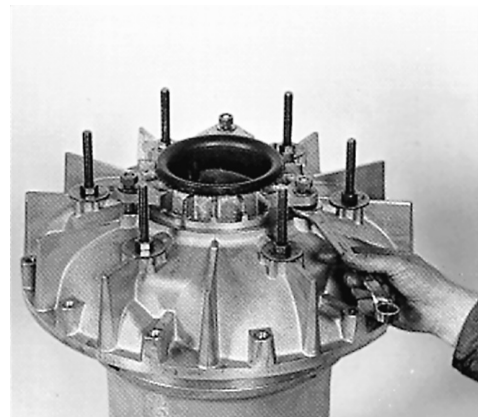
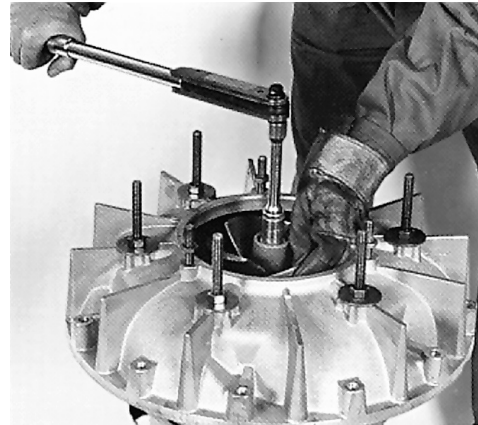
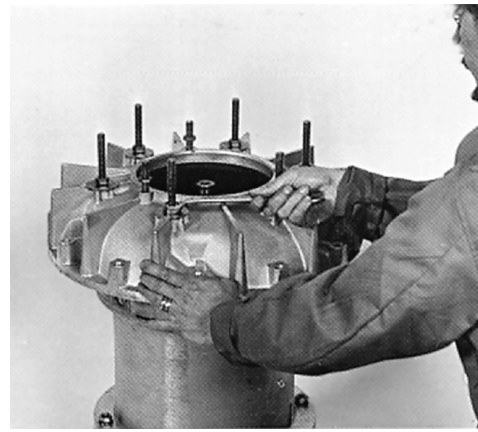

Turn over the pump and fit the spring assemblies consisting of spacer sleeves, rubber bushes and coil springs.



Install the strainer.

In order for the pump to perform at maximum capacity, the impeller must be adjusted regularly.

It is particularly important that the clearance between the lower diffuser and the impeller is kept to a minimum.



ACCESSORIES AND TOOLS

Tandem operation

The delivery head can be increased by connecting two or three pumps in tandem.

Max. permissible operating pressure is 1.0 MPa (145 psi).

The vertical distances between the pumps should be approximately equal.

See special brochure that describes the procedure for tandem connection.

The following complete connection units are available for tandem connection:

Order No.	Intended for
298 95 00	4"
298 95 01	R4"
298 95 02	NPSM 4-8
298 95 03	6"
298 95 04	R6"
298 95 05	NPSM 6-8

In case of tandem operation, the strainer is replaced with a connection unit.

Zinc anode set

In order to reduce corrosion on the pump, it can be fitted with zinc anodes.

Order No. 336 18 00

Assembly drawing included with set.

Level sensor

Xylem supplies level sensors suited for different liquid densities and with different cable lengths.

See separate brochure.

Start and control equipment

Xylem has suitable start and control equipment for the pump. Contact Xylem for further information.

Tools

Besides ordinary standard tools, the following tools are required in order to perform the necessary care and maintenance of the pump:

Order No.	Denomination
81 40 21	Screw
84 13 60	Puller

FAULT TRACING (Troubleshooting)

A universal instrument (VOM), a test lamp (continuity tester) and a wiring diagram are required in order to carry out fault tracing on the electrical equipment.

Fault tracing shall be done with the power supply disconnected and locked off, except for those checks which cannot be performed without voltage.

Always make sure that there is no one near the pump when the power supply is turned on.

Use the following checklist as an aid to fault tracing. It is assumed that the pump and installation have formerly functioned satisfactorily.

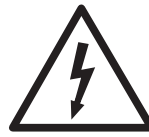

Electrical work shall be performed by an authorized Xylem service electrician.

Follow local safety regulations and observe recommended safety precautions.

1. Pump fails to start

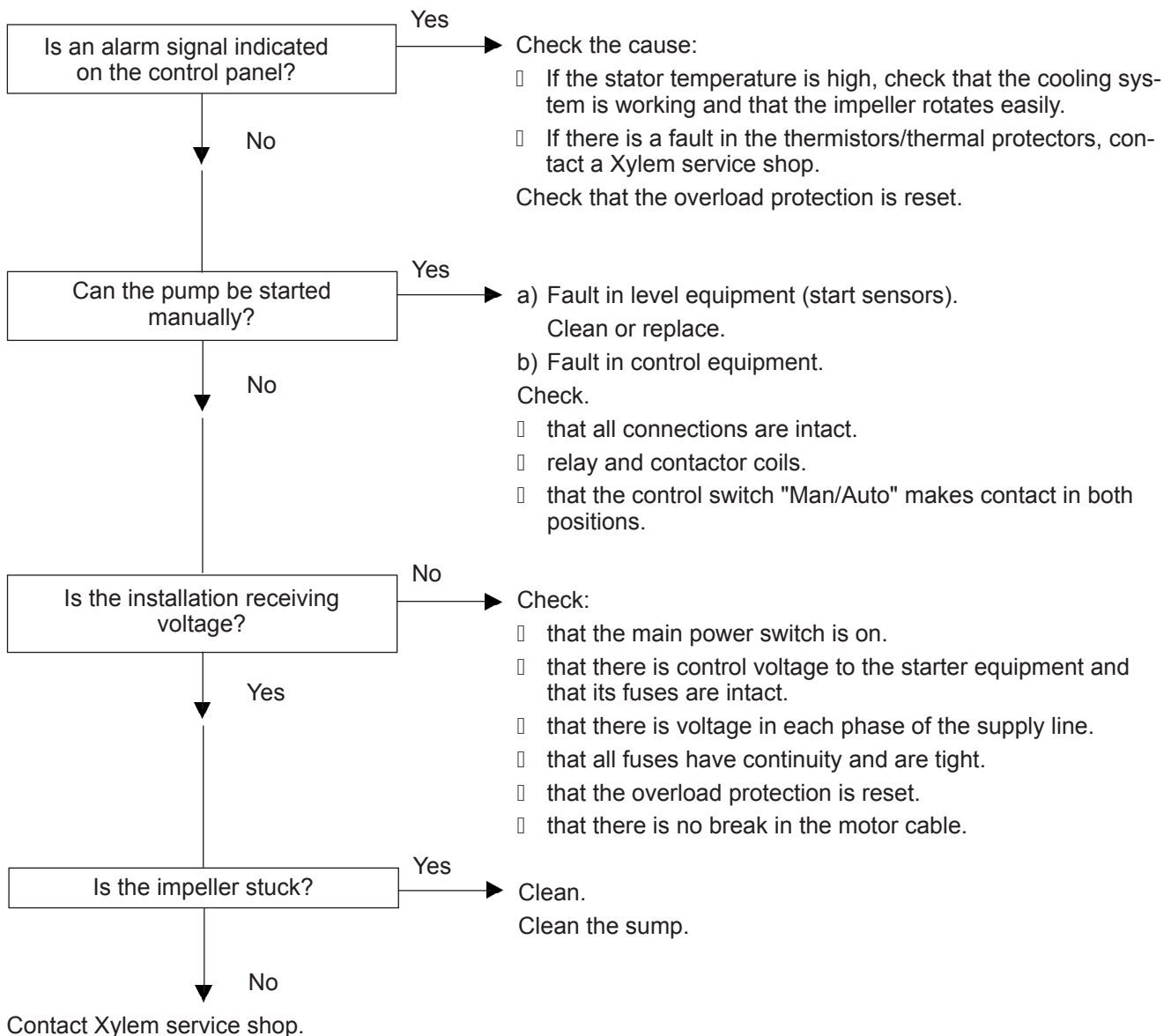

WARNING!
Disconnect power before checking the impeller.

2. Pump starts but motor protection trips

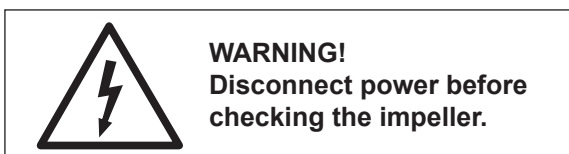
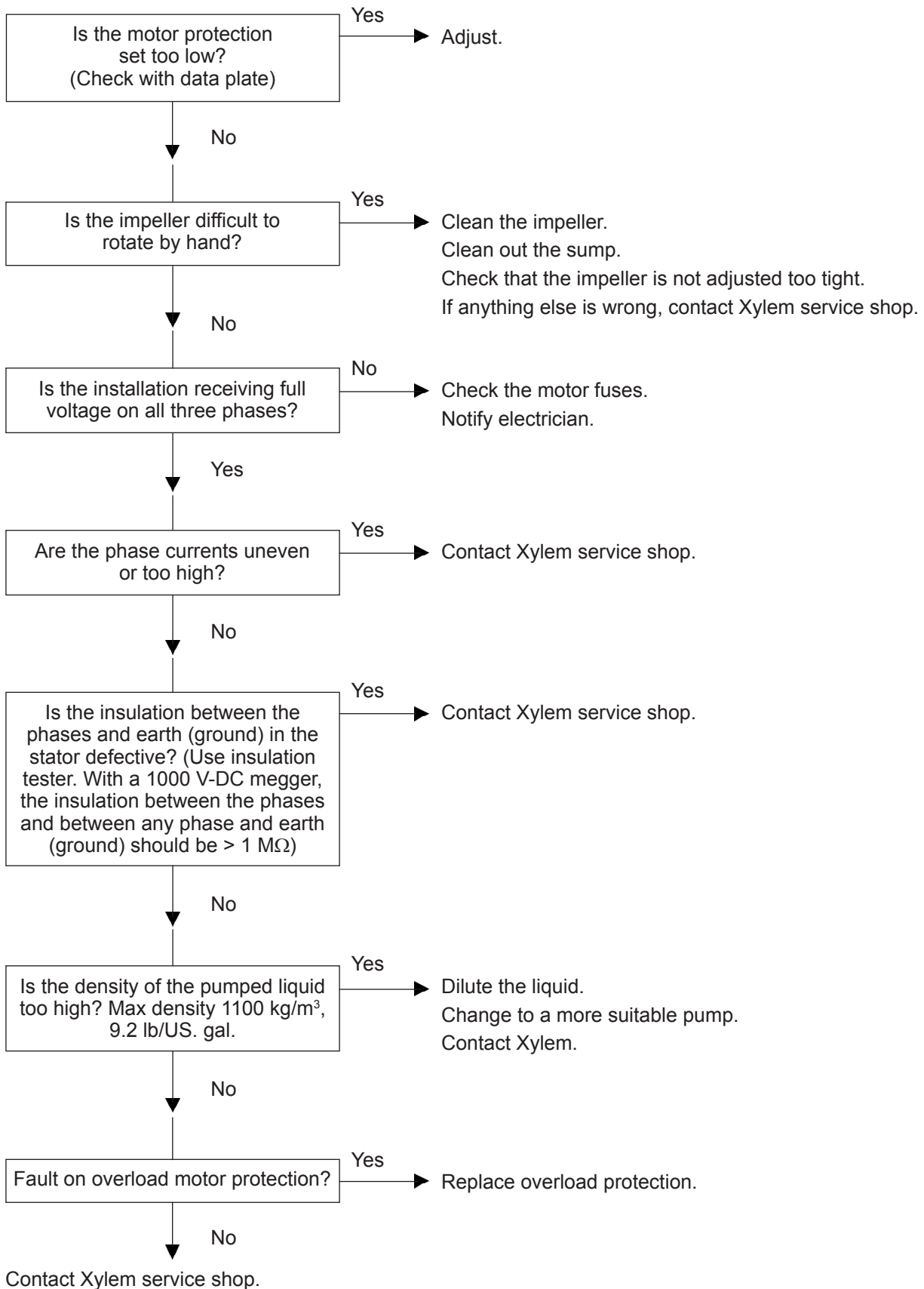

3. The pump does not stop (when using level equipment)

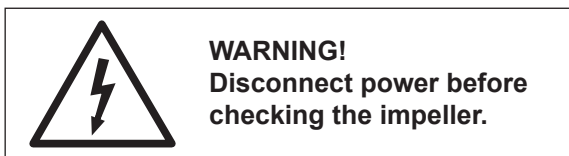
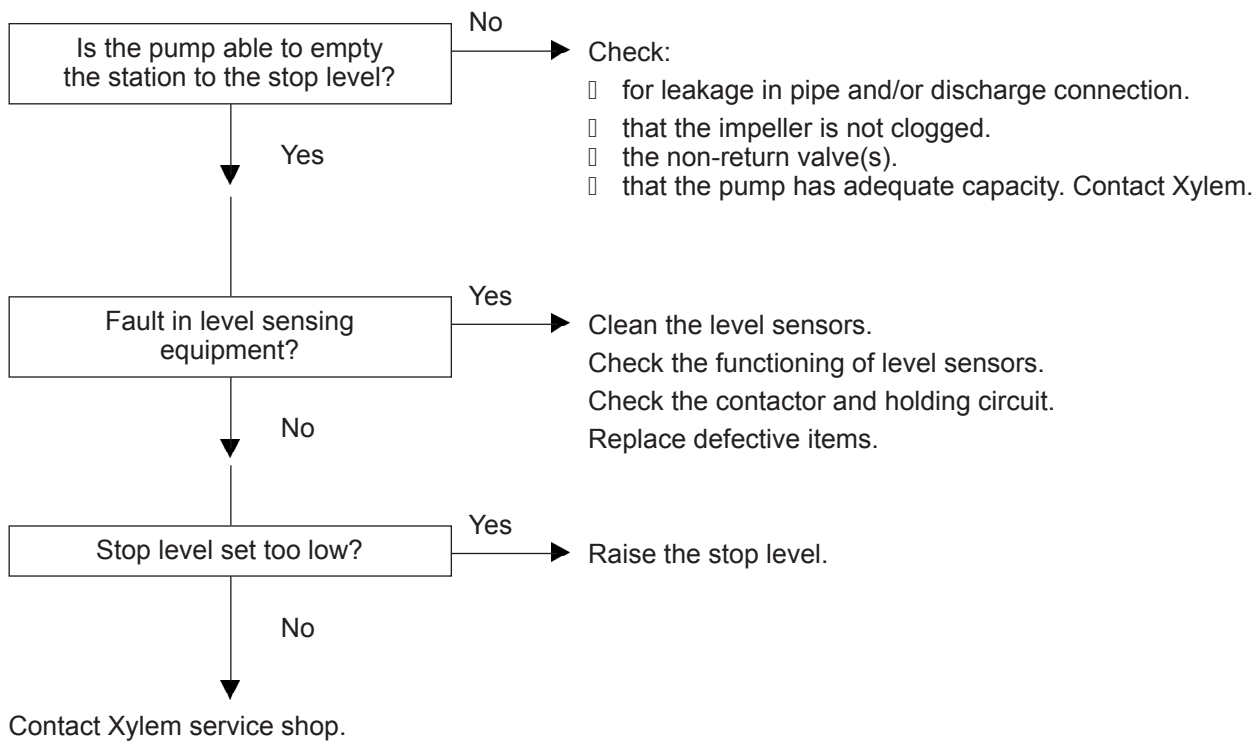

4. The pump starts-stops-starts in rapid sequence

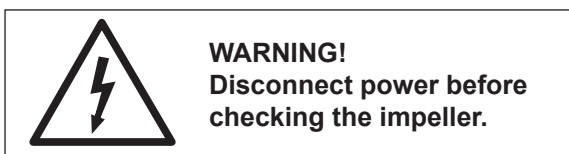
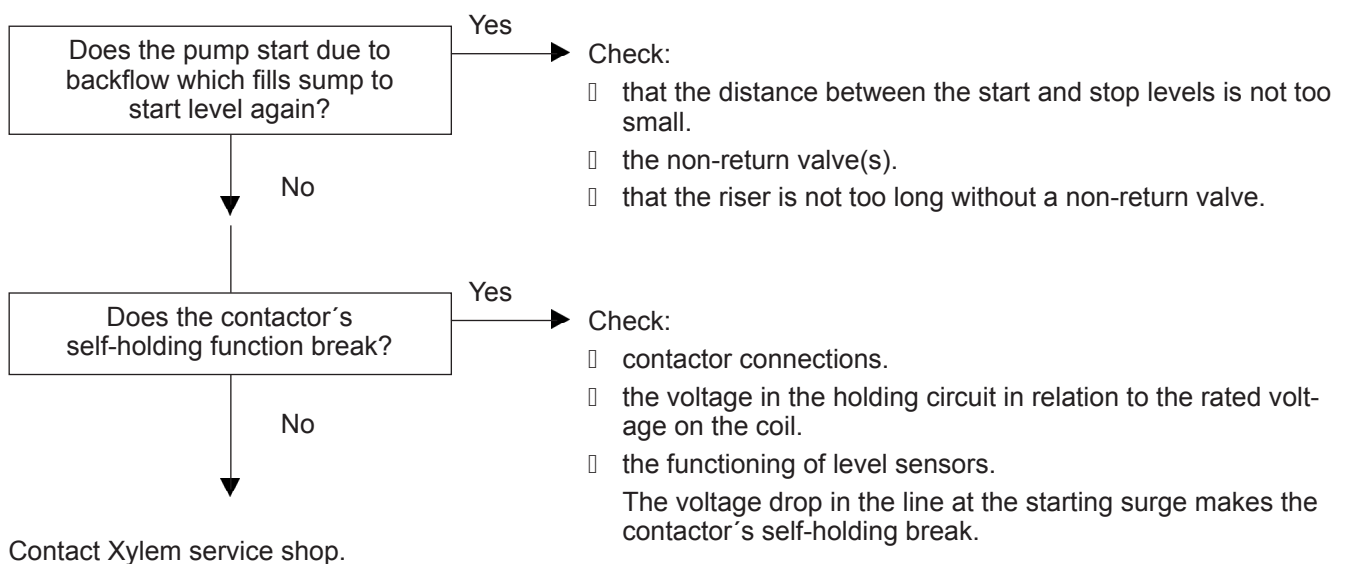

5. Pump runs but delivers too little or no water

Check:

- direction of rotation of pump, see "Before starting".
- that the valves are open and intact.
- that pipes, impeller and strainer are not clogged.
- that the impeller rotates easily.
- that the suction lift has not been altered.
- for wear on wear ring, impeller, pump casing/flange, suction bottom, diffuser disc, diffuser.

See also under "Inspection".

Do not override the motor protection repeatedly if it has tripped.

SERVICE LOG

Most recent service date	Pump No.	Hours of operation	Remarks	Sign.

SERVICE LOG

Most recent service date	Pump No.	Hours of operation	Remarks	Sign.

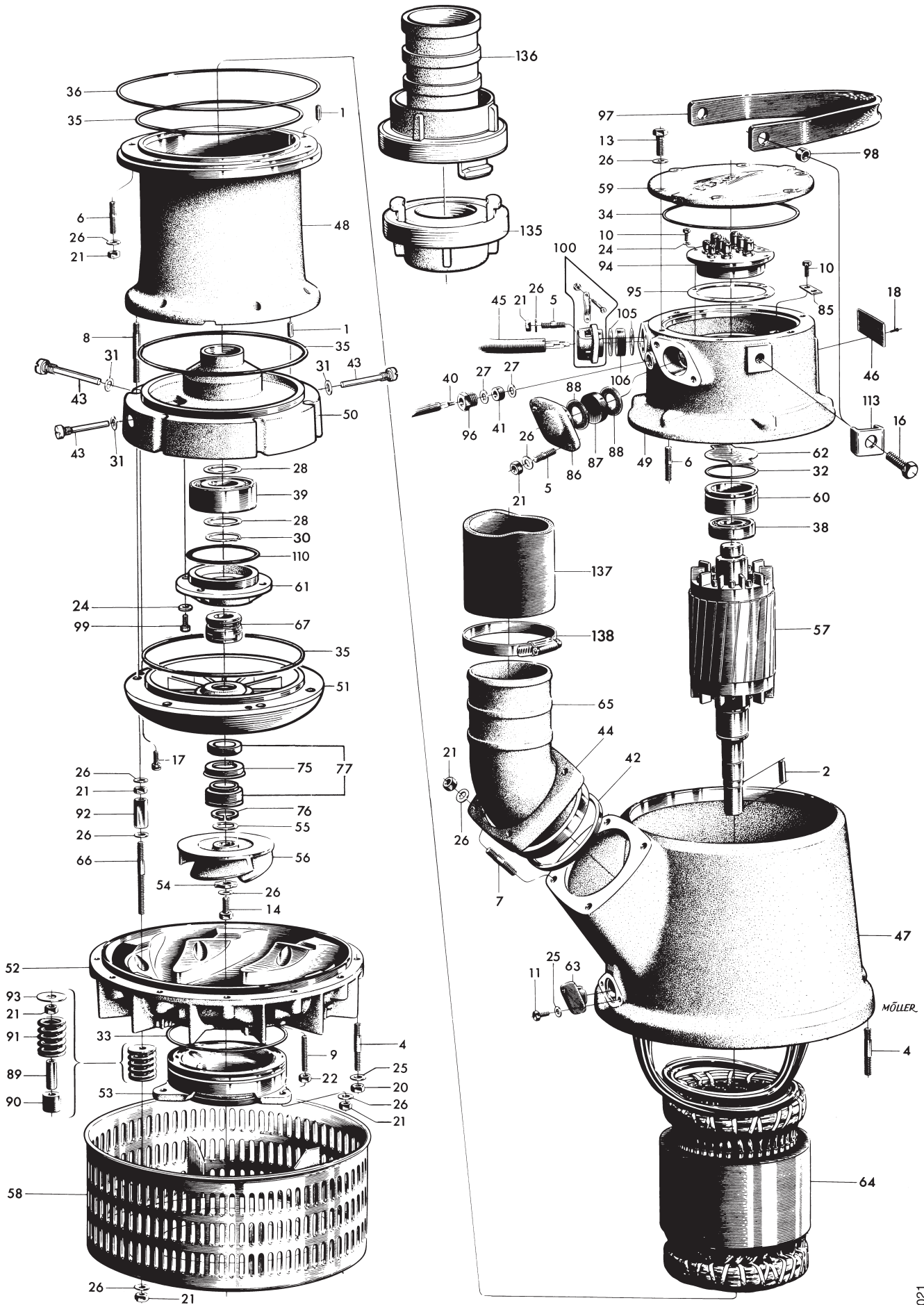

Xylem |'zīləm|

- 1) The tissue in plants that brings water upward from the roots;
- 2) a leading global water technology company.

We're 12,500 people unified in a common purpose: creating innovative solutions to meet our world's water needs. Developing new technologies that will improve the way water is used, conserved, and re-used in the future is central to our work. We move, treat, analyze, and return water to the environment, and we help people use water efficiently, in their homes, buildings, factories and farms. In more than 150 countries, we have strong, long-standing relationships with customers who know us for our powerful combination of leading product brands and applications expertise, backed by a legacy of innovation.

For more information on how Xylem can help you, go to www.xyleminc.com

Refer to www.xylemwatersolutions.com/contacts/ for contact details of your local sales and service representative.



Xylem Water Solutions Global
Services AB
361 80 Emmaboda
Sweden
Tel: +46-471-24 70 00
Fax: +46-471-24 47 01
<http://tpi.xyleminc.com>

Visit our Web site for the latest version of this document.

The original instruction is in English. All non-English instructions are translations of the original instruction.

© 2015 Xylem, Inc.

890243_14.0_EN-GB_2015-09_IOM_2151_011