



# Technical specification

Submersible pump B 2140, 50 Hz



Flygt





# BIBO 2140

## Product

Submersible pump for dewatering building yards, draining water in flooded areas, and other similar applications. The pump can handle water containing relatively abrasive solids.

## Denomination

Product code	2140.010
Installation	S
Impeller characteristics	MT

## Process data

Liquid temperature	max +40 °C
Depth of immersion	max 20 m
The pH of the pumped liquid	pH 5 - 8
Liquid density	max 1100 kg/m <sup>3</sup>
Strainer hole size	6 mm x 50 mm

## Motor data

Frequency	50 Hz
Insulation class	H (+180 °C)
Voltage variation	
- continuously running	max ± 5%
- intermittent running	max ± 10%
Voltage imbalance between phases	max 2%
No. of starts/hour	max 30

## Cable

### Direct-on-line start

SUBCAB®	4G4+2x1,5 mm <sup>2</sup>
	4G6+2x1,5 mm <sup>2</sup>

### Y/D start

SUBCAB®	7G2,5+2x1,5 mm <sup>2</sup>
	7G4+2x1,5 mm <sup>2</sup>

## Monitoring equipment

Thermal contacts opening temperature	125 °C
--------------------------------------	--------

## Material

Impeller	High chrome alloyed cast iron
Wear parts	Nitrile rubber
Stator housing	Aluminium
Strainer	Galvanized steel
Shaft	Stainless steel
O-rings	Nitrile rubber

### Mechanical face seals

Alternative	Inner seal	Outer seal
1	Corrosion resistant cemented carbide/ Corrosion resistant cemented carbid	Corrosion resistant cemented carbide/ Corrosion resistant cemented carbid

### Surface Treatment

The pump top is sprayed with blue paint.

## Weight

See dimensional drawing.

## Option

Polyurethane-lined wear parts	POLY-LIFE®
Other cables	
Zinc anodes	
Tandem connection	

## Accessories

Adapters, hose connections and other mechanical accessories.

Electrical accessories such as pump controller, control panels, starters, monitoring relays, cables.

See separate booklet or [www.flygt.com](http://www.flygt.com), for further information.

**MT-Motor rating and performance curve**

Curve/Impeller No	Rated Power, kW	Rated current, A	Starting current, A	Power factor $\cos \phi$	Ex proof version available
<b>400 V, 50 Hz, 3 ~, 2885 r/min</b>					
231	12	23	186	0,86	
232	12	23	186	0,86	

*Y/D starting current is approximately 1/3 of D starting current.*

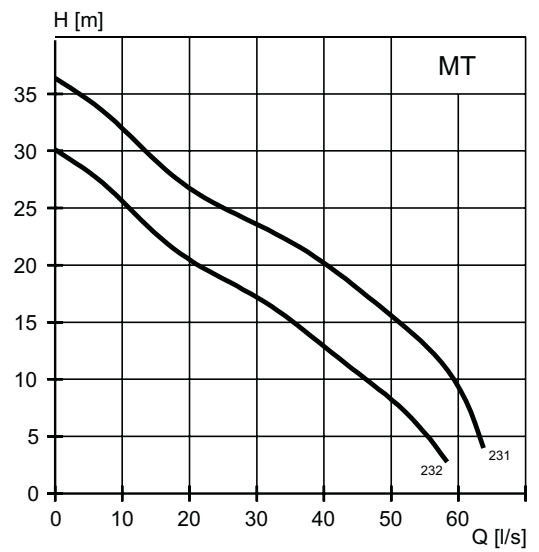
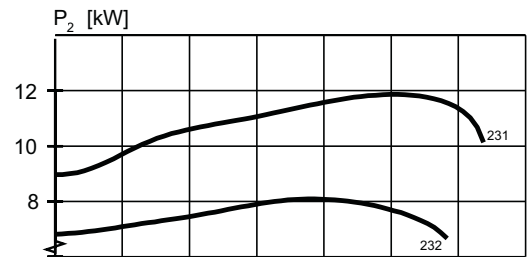

**Dimensional drawing**

All drawings are available as Acrobat documents (.pdf) and AutoCad drawings (.dwg). Download the drawings from [www.flygt.com](http://www.flygt.com) or contact your ITT Flygt representative for more information.

All dimensions are in mm.

**MT, S-installation**

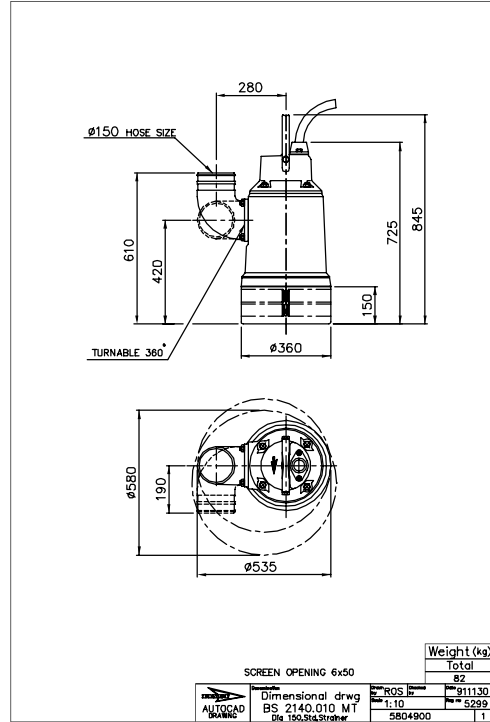

**MT, S-installation**

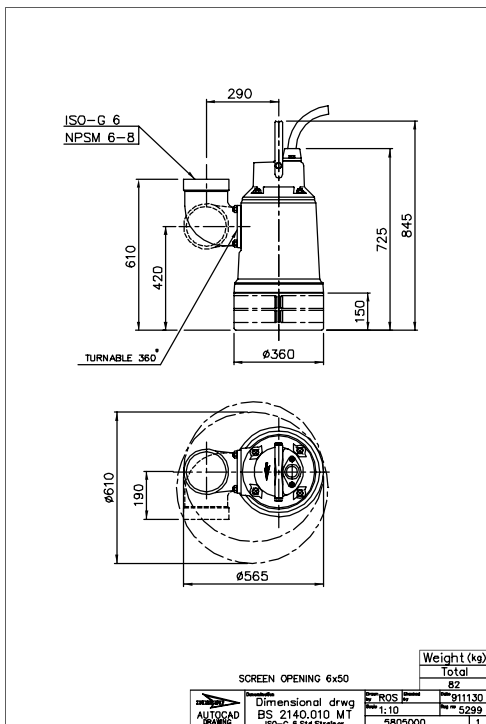

**MT, S-installation**

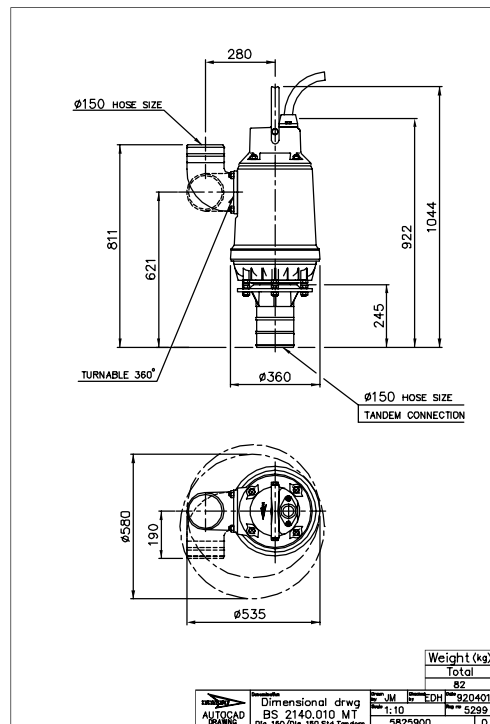

## HT, S-installation

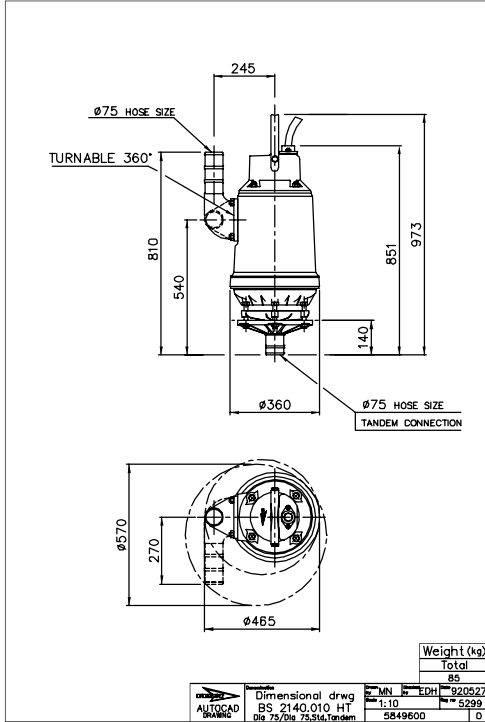

## HT, S-installation

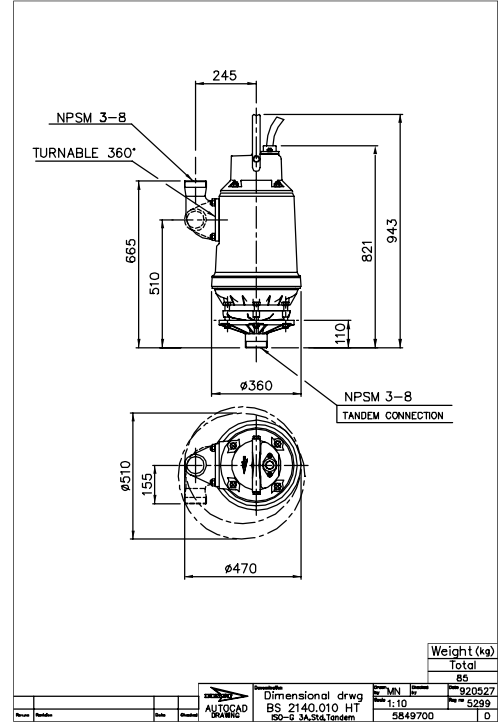

## HT, S-installation

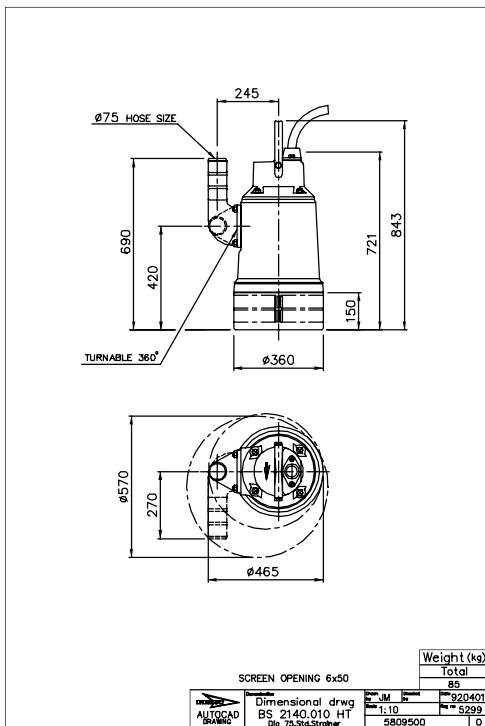

## HT, S-installation

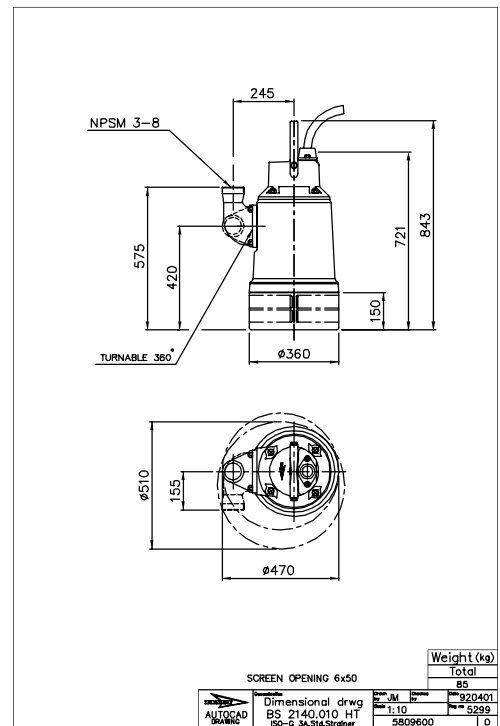

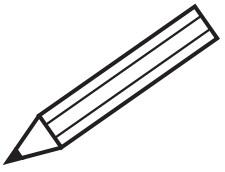

---

A series of horizontal dashed lines for writing, starting below the pencil illustration and extending to the bottom of the page.





[www.flygt.com](http://www.flygt.com)